

Thank you for purchasing genuine NightRider™ LEDS.

Please use the following diagrams for wiring your new beacon or strobe light to the momentary actuator switch (NSB-WSM).

### WIRING BEACONS to Momentary Actuator Switch

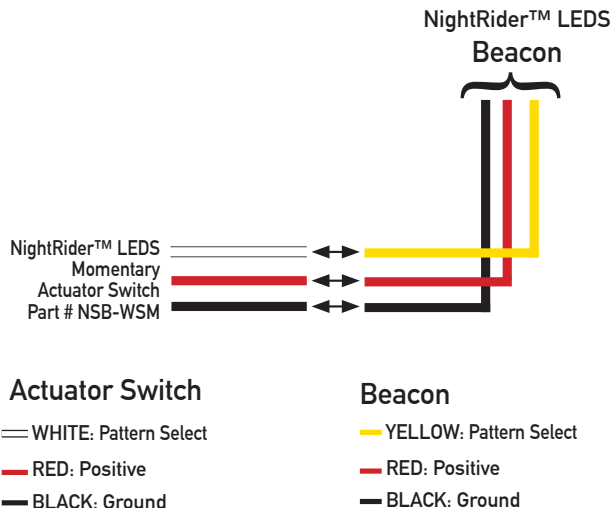

### WIRING LOW PROFILE STROBE LIGHT to Momentary Actuator Switch (Synchronisation of lights is available)

Up to 12 Units of NSB-S262(AMB/AB/R) can be wired & synchronized together.

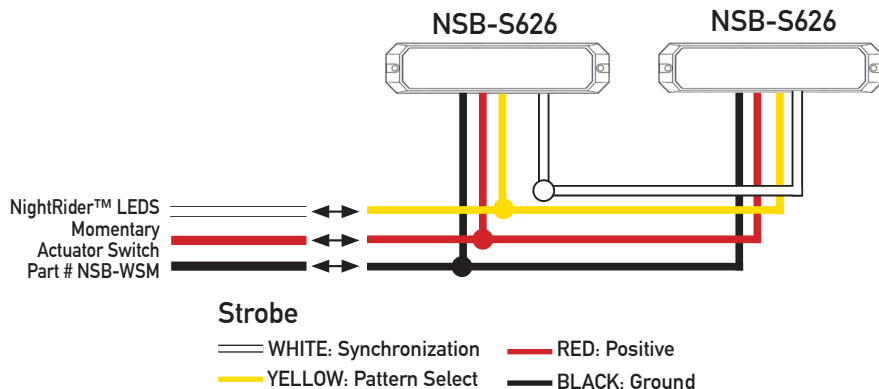

NightRider™ LEDS takes no responsibility for incorrect installation and/or damages related. This guide is for reference purposes only. If unsure about your electrical system, contact your dealer or qualified professional automotive/equipment technician. It is the vehicle operator's responsibility to ensure all product installations are properly, safely and legally installed in accordance to regional regulations of use.

For more information contact your local dealer. Find a dealer: [www.nightriderleds.com](http://www.nightriderleds.com)