

CONGRATULATIONS AND THANK YOU FOR PURCHASING GENUINE NIGHTRIDER™ LEDS.

NightRider™ LEDS is proud to provide you the NightDriver™ Series Professional Street Legal* LED lighting.

PLEASE READ ALL INFORMATION IN THIS DOCUMENT BEFORE INSTALLATION AND USE.

NightRider™ LEDS products are designed to be easily installed by qualified professional automotive technicians.

Please remember it is the vehicle owner's responsibility to ensure all product installations are properly, safely and legally installed in accordance to the regional regulations of use. NightRider™ LEDS takes no responsibility for incorrect installation and/or any related damages.

WARNING!

Only use the included NightRider™ LEDS recommended wiring harness to wire NightRider™ LEDS lights. NightRider LEDS lights have unique circuitry that can easily be damaged when using wiring not built for NightRider™ LEDS lights. If ever unsure contact your dealer or a qualified professional automotive/equipment technician.

Recommended Installation

The following installation procedures are for guidance only, not to be used in place of regional regulations and safety measures.

All screws, bolts and nuts used in the installation of NightRider™ LEDS lamps and mounting hardware should be tightened snug and checked after the first 30km for secure fitment. NightRider™ LEDS recommends using a medium strength liquid or gel thread-locker.

Wiring NightDriver Auxiliary Driving Lights to Vehicle High Beams

(Required in most North American Jurisdictions)

NightRider™ Side Shooter Lights with Amber Warning Lights

Image 1

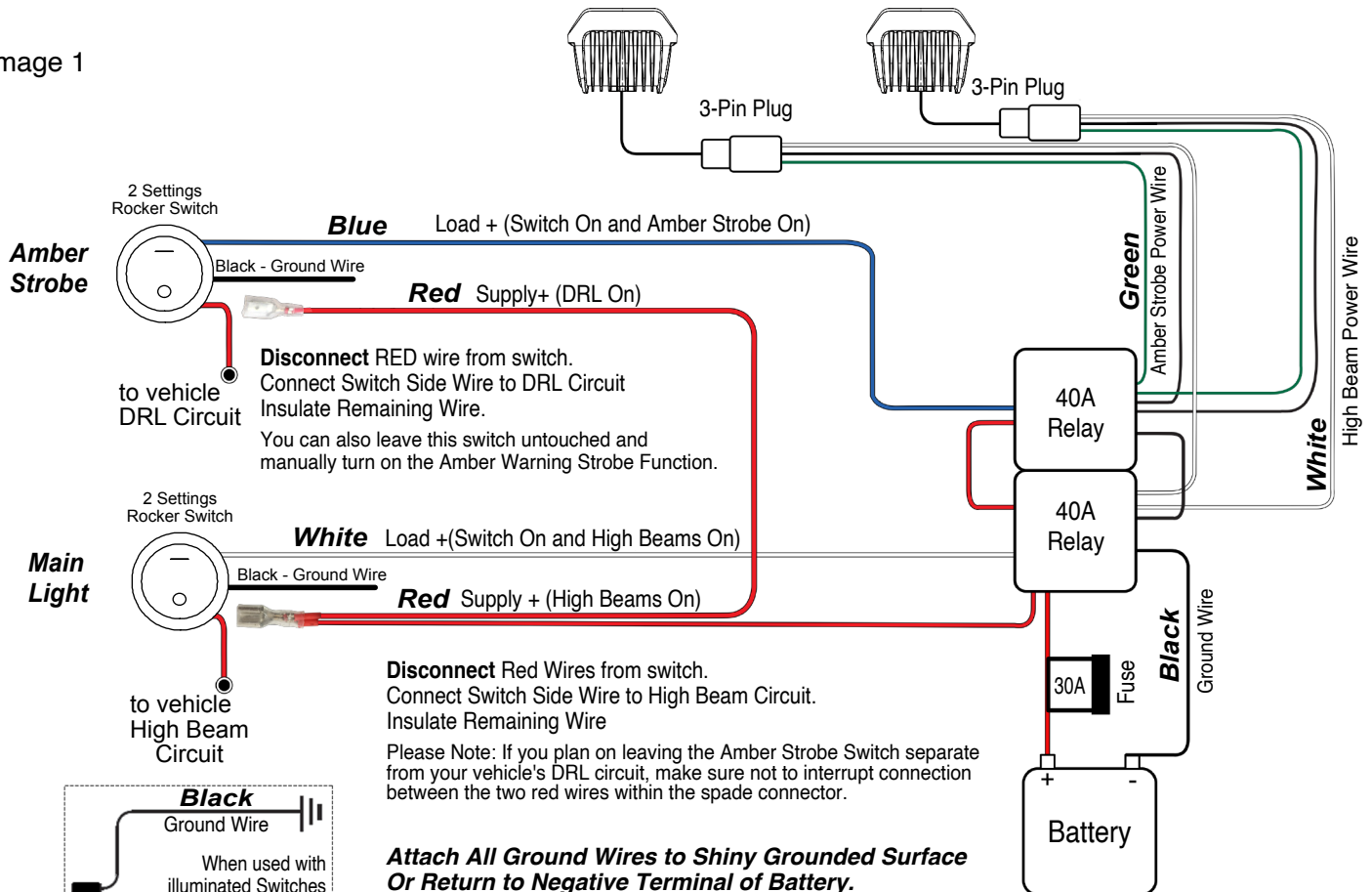

*Always check with regional rules and regulations regarding the use of auxiliary driving lights. NightRider™ LEDS strives to deliver the safest and most lawful lights, but cannot be held accountable for regional restrictions, improper mounting, aiming, or wiring.

NightRider™ LEDS

AUXILIARY LIGHT MOUNTING POSITION AND BEAM AIM

The mounting and aiming illustrations below are for **reference and guidance only**.

Always refer to the applicable rules and regulations in the region you are using auxiliary driving lights.

Image 2. Excerpt from the Motor Vehicle Act of British Columbia, Canada.

Auxiliary driving lamps

4.09

- (1) A motor vehicle may be equipped with 2 auxiliary driving lamps, mounted on the front of the vehicle at a height of not less than 40 cm and not more than 1.06 m, that are capable of displaying only white light.
 - (2) An auxiliary driving lamp must be directed so that the high intensity portion of the beam is, at a distance of 8 m from the lamp, at least 12 cm below the height of the lamp and, at a distance of 25 m from the lamp, not higher than 1.06 m from the road surface.
 - (3) An auxiliary driving lamp must operate so that it is illuminated only when the upper beam of a multiple beam headlamp is illuminated.
- [en. B.C. Reg. 476/98, s. 2.]

Image 2

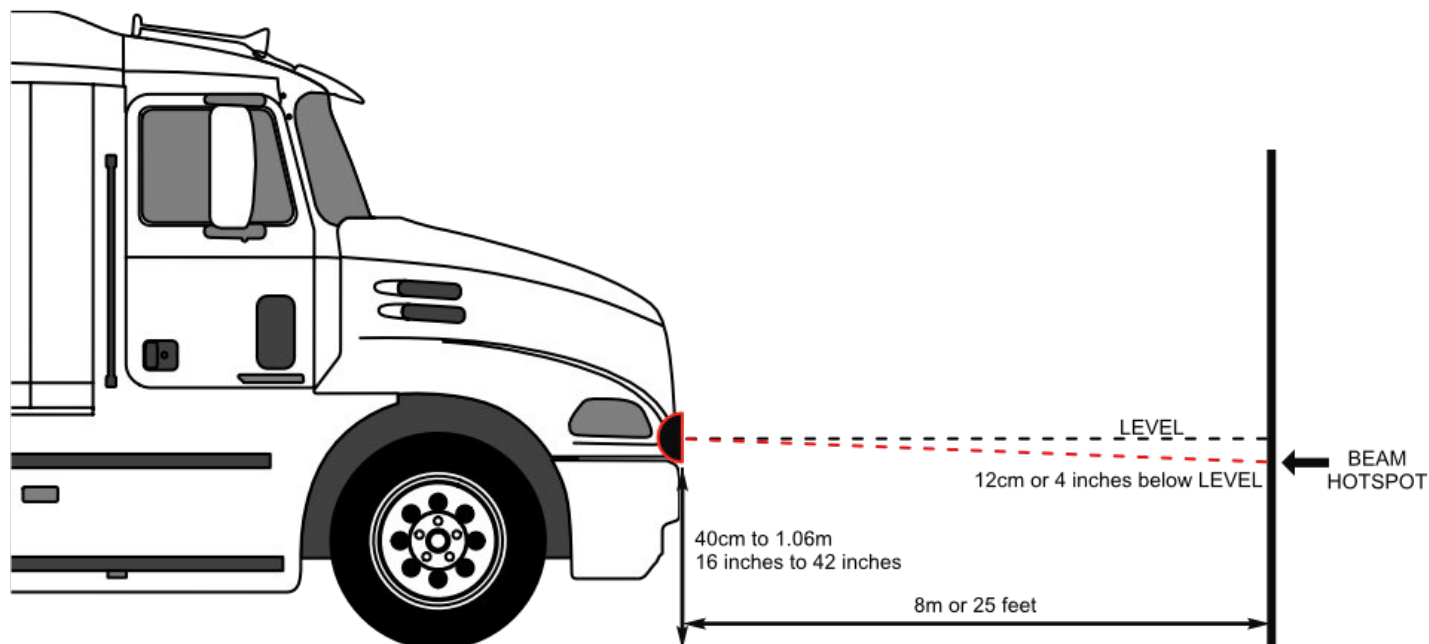

Upon request NightRider™ LEDS will supply the appropriate SAE or ECE test report for your **NightDriver™ Series** LED Light to an authorized authority for inspection and confirmation of compliance.